

YMS55

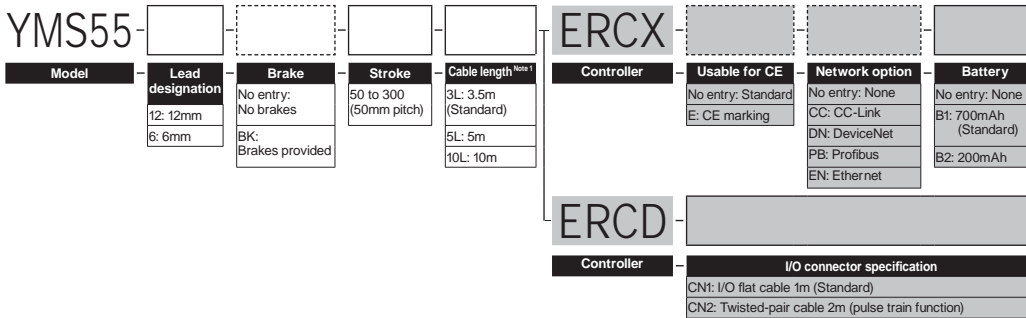

Ordering method



Note 1. The robot cable is standard cable, but can be changed to bend-resistant cable. (consult factory)

Specifications

AC servo motor output (W)	30	
Repeatability (mm)	+/-0.02	
Deceleration mechanism	Ball screw $\phi 12$ (Class C10)	
Ball screw lead (mm)	12 6	
Maximum speed ^{Note 1} (mm/sec)	600 300	
Maximum payload (kg)	Horizontal	5 9
	Vertical	1.5 4
Rated thrust (N) ^{Note 2}	32 64	
Stroke (mm)	50 to 300 (50mm pitch)	
Cable length (m)	Standard: 3.5 / Option: 5,10	
Linear guide type	-	
Position detector	Resolvers	
Resolution (Pulse/rotation)	16384	

Note 1. Be sure that radial loads are not applied to the rod.

Note 2. When the stroke is 300mm, the maximum speeds are 450mm/sec and 225mm/sec (75%).

Note 3. The thrust control accuracy is not guaranteed.

Controller

Controller	Operation method
ERCD	Pulse train control / Programming / I/O point trace (BCD)/ Remote command / Operation using RS-232C communication
ERCX (4.5A) ^{Note}	Programming / I/O point trace (BCD)/ Remote command / Operation using RS-232C communication

Note 1. This is the required power supply capacity. An insufficient power supply capacity can reduce performance.

YMS55 Brakes provided type

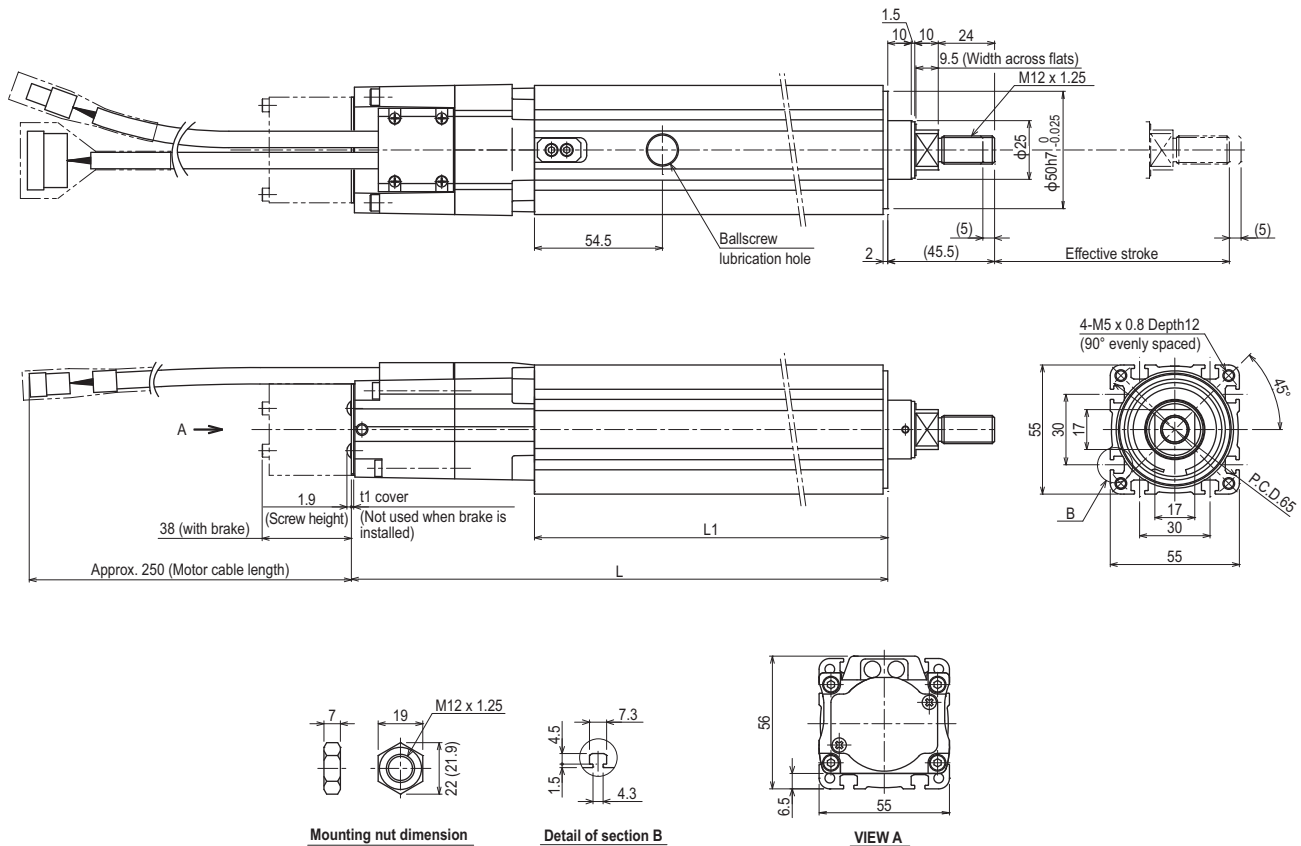

Effective stroke	50	100	150	200	250	300
L1	150.5	200.5	250.5	300.5	350.5	400.5
L	228.5	278.5	328.5	378.5	428.5	478.5
Weight (kg) ^{Note}	1.7	2.0	2.4	2.7	3.1	3.4

Note 1. Weight of models with no brake. The weight of brake-attached models is 0.2 kg heavier than the models with no brake shown in the table.